



ZHM 230P

Polycrystalline Solar Module

- Certificates: TUV, VDE, MCS, IEC 61215/61730, UL1703, CEC, CE, ISO
- 10 years product defect warranty
25 years power output warranty: 90% in 10 years, 80% of 25 years
Module is certified to withstand high wind loads
(2400 Pascal) and snow loads(5400 Pascal)
- Power tolerance: 0~+3%
- Cell: High efficiency solar cells
- Standard waterproof junction box, with bypass diode, which protects the module from burning caused by hot-spot effect because of shading
- 3.2mm high transmission tempered glass
- Anodized aluminum alloy frame (Available Depth: 35/45/50mm)



UE Solar Co., Ltd is a manufacturer of high quality mono- and multi-crystalline silicon PV modules in East China; with an annual capacity of 300MW. Our 860 research staff and workers dedicate themselves to providing inexhaustible and renewable energy.



Electrical Performance

ZHM-230P			ZHM250P	ZHM245P	ZHM240P	ZHM235P	ZHM230P	ZHM225P	ZHM220P	ZHM215P	ZHM210P	ZHM205P	ZHM200P
Peak power	Pmax	Wp	250	245	240	235	230	225	220	215	210	205	200
Maximum power voltage	Vmp	V	31.1	30.9	30.5	30.2	30.1	30	29.7	29.4	29	28.5	28.3
Maximum power current	Imp	A	8.04	7.92	7.87	7.78	7.67	7.50	7.41	7.31	7.24	7.19	7.06
Short circuit current	Isc	A	8.84	8.72	8.66	8.56	8.45	8.25	8.15	8.05	7.94	7.91	7.77
Open circuit voltage	Voc	V	37.32	37.08	37.64	37.27	37.14	37.02	36.65	35.57	35.09	34.49	34.24
Cell efficiency	%		17.12	16.78	16.44	16.09	15.75	15.41	15.07	14.72	14.38	14.04	13.70
Module efficiency	%		15.40	15.09	14.78	14.47	14.17	13.86	13.55	13.24	12.93	12.63	12.32

Standard Test Condition: (STC)STC: T=25°C AM=1.5 E=1000W/m²

Working Conditions & Parameters

Maximum system Voltage (V)	1000 V
Power tolerance	0~+3%
Cell dimension	156*156mm
Number of cells / Layout	60pcs. /10*6
NOCT cell	48 °C ± 2 °C
Temperature coefficient Isc (%)	+0.04±0.015 % / °C
Temperature coefficient Voc (%)	- (0.35±0.02) % / °C
Temperature coefficient Pm (%)	- (0.5±0.05) % / °C
Temperature coefficient Im (%)	+0.04% / °C
Temperature coefficient Vm (%)	-0.38% / °C
Operating temperatures	-40°C ~+90 °C
Surface pressure	60m/s (200kg /m ²)

I-V Curve

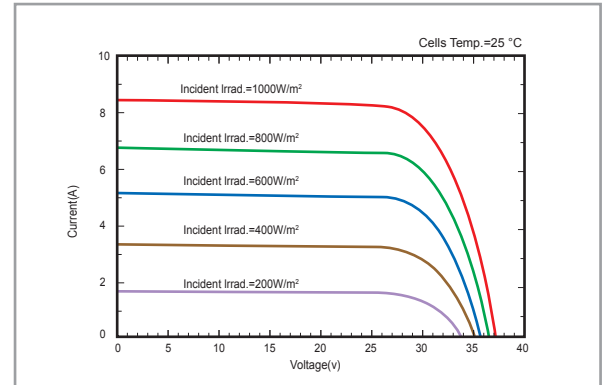

Length	Width	Depth	Weight
1640mm	990mm	50mm	20Kg

Packaging

- 23 modules / 1 cardboard box(up)
- 20 modules / 1 cardboard box(down)
- 1 cardboard box / 1 pallet

Container loading capacities

Container 40" (HIGH): 559 modules / 26 pallets

Front and Back View

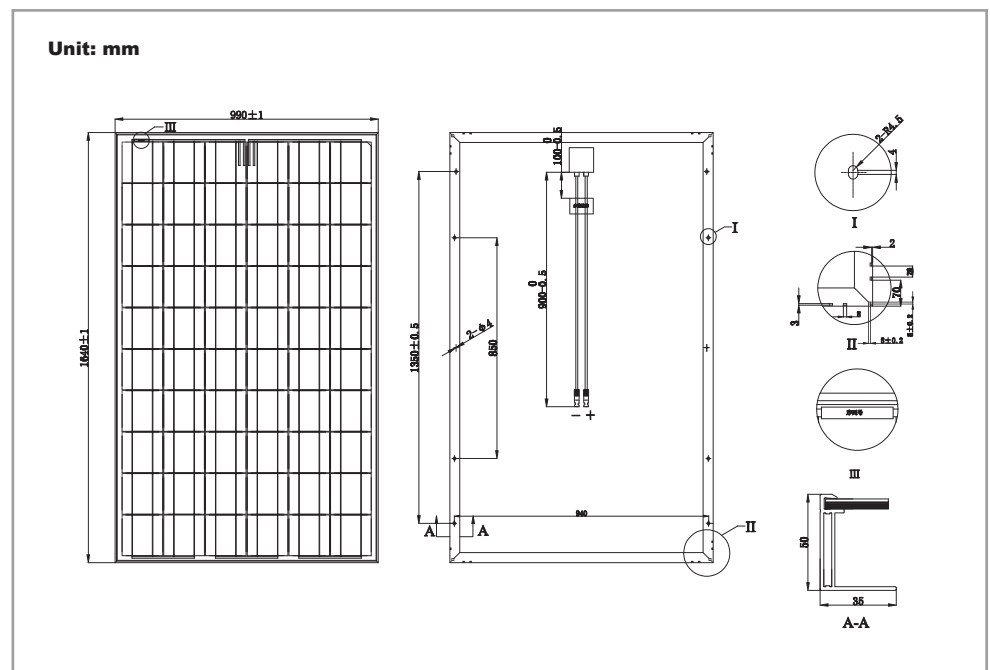

UE Solar Co.,Ltd All rights reserved.

Specifications and designs included in this are subject to change without notice